

GUARDIAN COMPACT WALL PACK LED 50W / 5,418LM

The LED 50W GUARDIAN COMPACT WALL PACK fixture achieves 5,418 LUMENS.

The LED 50W GUARDIAN COMPACT WALL PACK fixture provides substantial light from a small package. Utilizing chip on board (COB) technology, multiple LED chips are bonded directly to the substrate to form a single module. This packaging takes less space and obtains the full potential of the LED chips.

Simple installation into new or existing applications due to its small package, this LED wall pack fixture offers a warm, consistent lighting solution for any outdoor, vertical space.

APPLICATION

This outdoor wall pack fixture is ideal for any application requiring nondescript lighting, including residential, historic area, park, shopping mall, and courtyard applications.

FEATURES & BENEFITS

- 10-year Limited Warranty
- Silicon rubber gasket seal
- UV resistant, polycarbonate lens
- Soft and warm surface light, no shadow
- High thermal conductive material
- Highly efficient cooling system

LED & OPTICAL ASSEMBLY

- Cree LED Chip On Board (COB) Emitters
- 75+CRI
- LM79 Tests in accordance with IESNA standards

APPROVALS / LISTINGS

- DLC Listed
- IP65 Rated
- ETL Listed to UL1598
- Temperature rated -40°C to 40°C
- CE / RoHS compliant
- LM80 & TM21 data available on request

MATERIALS

- High pressure, diecast aluminum housing with a bronze, anti-static powder coat finish for improved corrosion resistance & heat transfer

SIZE / WEIGHT (PACKAGED)

6.0" x 10.8" x 11.8" (8.0" x 12.0" x 14.0")
 10.1 lbs. (11.1 lbs.)

MOUNTING

Designed for simple wall or adjustable yoke mount in new and retrofit applications.



ORDER INFORMATION

e.g., EL-LED-GDC-50-UL-X-50-CO

SERIES	WATTAGE	VOLTAGE	DIMMING	COLOR TEMP	CUT OFF	CORDS & OPTIONS
EL-LED-GDC	50					
EL-LED-GDC EVERLAST LED GUARDIAN COMPACT WALL PACK	50 WATT 5,418 LUMENS	UL UNIVERSAL (120-277V AC)	X NONE D 1-10V	50 5000K 75+CRI 40 4000K 75+CRI	CO CUT OFF	BTN1 120V BUTTON PHOTOCELL BTN2 208-277V BUTTON PHOTOCELL RAL9011 BLACK COLOR OPTION

GUARDIAN COMPACT WALL PACK LED 50W / 5,418LM

EMITTER (CREE) & DRIVER SPECIFICATIONS

SYSTEM WATTS (120-277V AC)	INITIAL DELIVERED LUMENS (5000K) 75+ CRI	NUMBER OF LEDS	TOTAL CURRENT / FIXTURE			
			120V AC	208V AC	240V AC	277V AC
50	5418	3 COB	0.42	0.24	0.21	0.18

INPUT

VOLTAGE RANGE	FREQUENCY RANGE	POWER FACTOR	TOTAL HARMONIC DISTORTION	EFFICIENCY (230V AC / 277V AC)
120-277V AC	50 / 60 Hz	>0.98	THD < 15% when Output Loading	

FACE

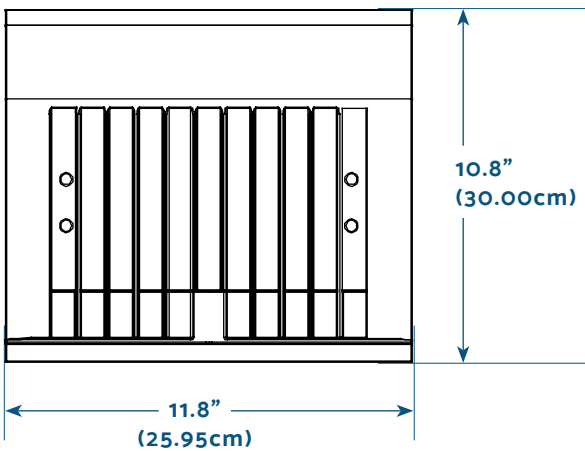

MOUNT

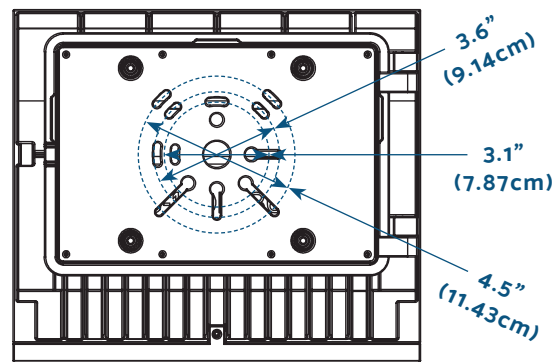

SIDE

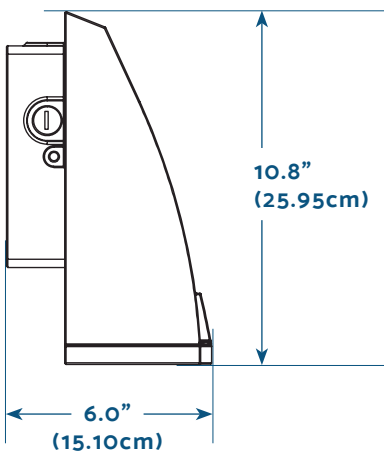

BOTTOM

