



Classic Bi-Level Wall Pack

Description

- Series: EOF-ED-BL
- Lamp Life Rating: 100,000 hours
- Light Output: 5000K, 82-85 CRI
- IP Rating: IP54
- Applications: Security lighting, buildings, parking lots
- Warranty: 10 Year Limited

Specifications and Patent Pending Features

- Bi-Level Ballast dims to 40% power for additional energy savings
- Die cast aluminum housing with bronze powder coat finish for corrosion-resistance
- Tempered glass lens and anodized aluminum reflector
- Electronic ballast with high power factor
- Excellent vibration & shock resistance

Ordering Information

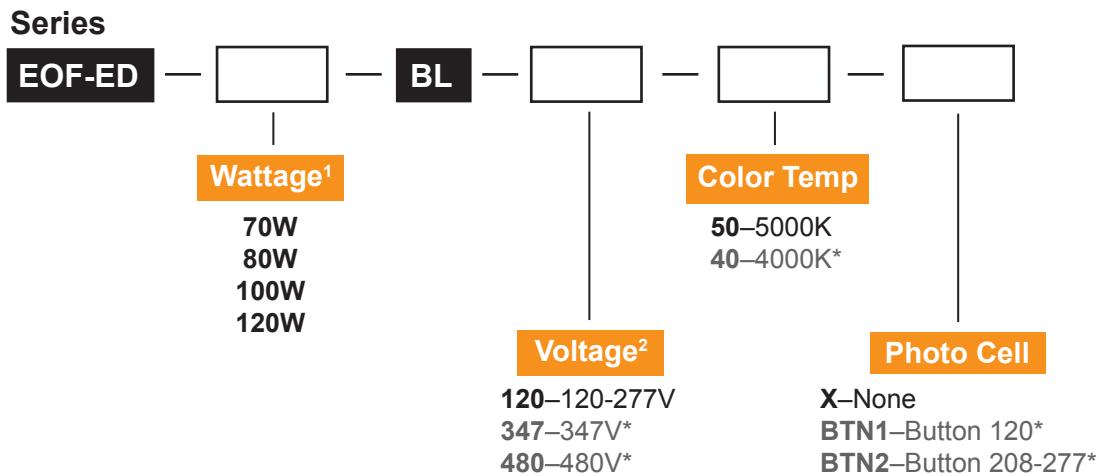

Bold = Standard
Grey * = Upgrade options available upon request

Example: **EOF-ED-70-BL-120-50-X**

*Legal Notice: Full Spectrum Solutions owns proprietary rights in the EverLast® Series of fixtures in the form of pending patent applications in the US and PCT applications for International protection.

Dimensions

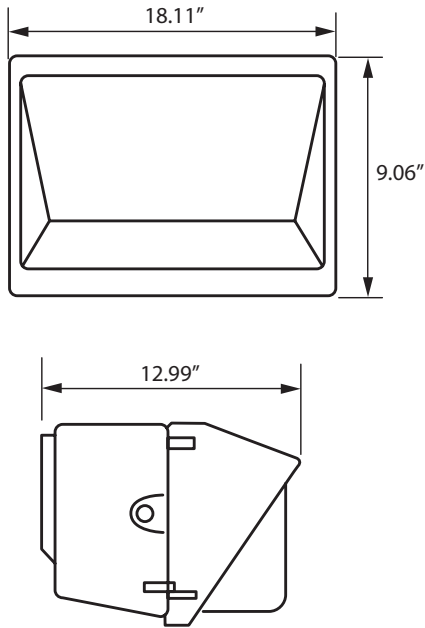

Photometric Data

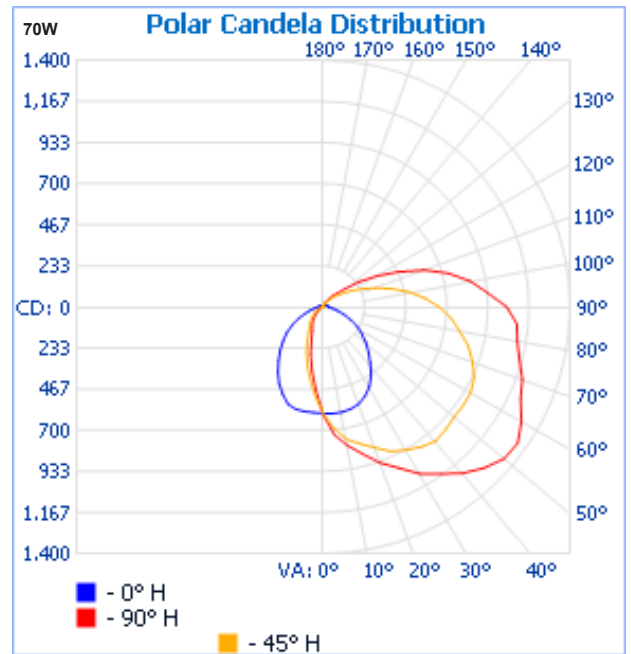

Lamp Specifications

Wattage	Lumens	L/W Ratio	CRI	CCT (KELVIN)	Rated Life
70W	5,900	84	82-85	5000	100,000 hours
80W	7,150	84	82-85	5000	100,000 hours
100W	8,400	84	82-85	5000	100,000 hours
120W	10,100	84	82-85	5000	100,000 hours

Ballast Specifications

System Wattage	Input Voltage	Input Current	Input Freq.	Power Factor	Ambient Temp	THD
78W	120-277V/480V*	0.63-0.29A/ 0.16A	50/60Hz	>0.95	-30 to 130 F°	<10%
90W	120-277V/480V*	0.70-0.32A/ 0.19A	50/60Hz	>0.95	-30 to 130 F°	<10%
111W	120-277V/480V*	0.93-0.42A/ 0.22A	50/60Hz	>0.95	-30 to 130 F°	<10%
134W	120-277V/480V*	1.05-0.46A/ 0.28A	50/60Hz	>0.95	-30 to 130 F°	<10%

Application Image - EOF-ED-BL

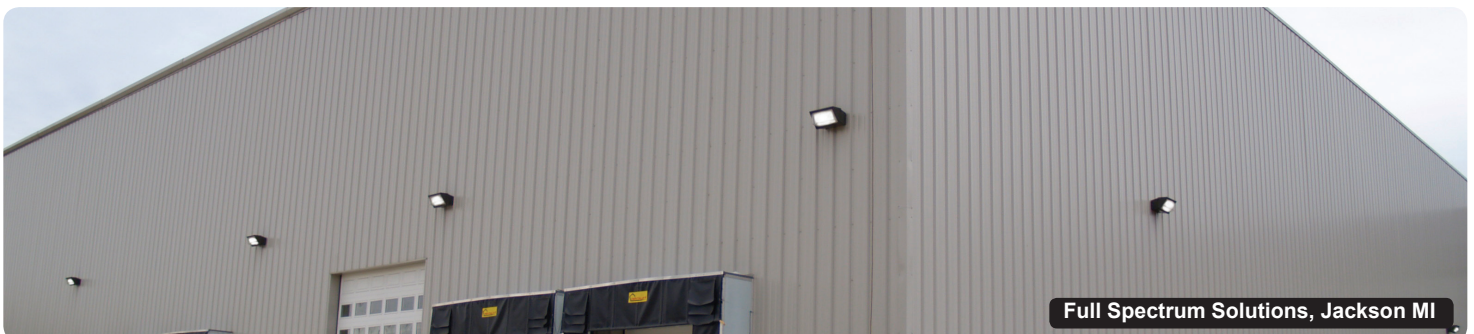

*Legal Notice: Full Spectrum Solutions owns proprietary rights in the EverLast® Series of fixtures in the form of pending patent applications in the US and PCT applications for International protection.