



Manufactured in U.S.A.
Per Buy American Act 41U.S.C.

*Patent Pending

Huron Aluminum High Bay

Description

- Series: EHBUS-AC
- Lamp Life Rating: 100,000 hours
- Lumen Maintenance: 70% over 100,000 hours
- Light Output: 5000K, 86-90 CRI
- IP Rating: IP43
- Applications: Warehouses, factories, retail showrooms, gymnasiums
- Warranty: 10 Year Limited

Specifications and Patent Pending Features

- 22 inch A3002-0 reflector with smooth Bright Dip Clear inner surface
- UV stabilized premium flat acrylic lens with <2% Haze
- Die cast aluminum ballast casing with corrosion-resistant white powder coat finish
- Simple latching hook or pendant mounting system
- Electronic ballast with high power factor, flicker free instant re-strike
- Excellent vibration & shock resistance

Ordering Information

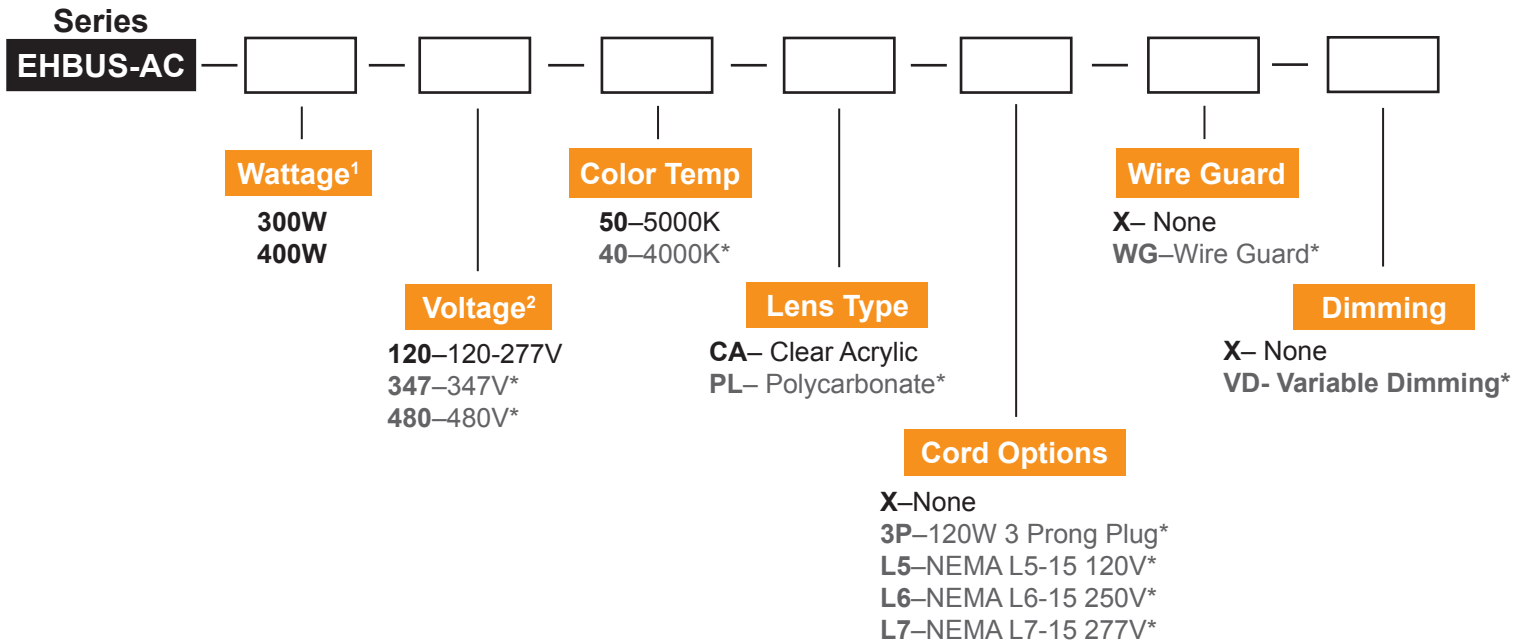

Bold = Standard
Grey * = Upgrade options available upon request

Example: Example: **EHBUS-AC-300-120-50-CA-3P-X-VD**

*Legal Notice: Full Spectrum Solutions owns proprietary rights in the EverLast® Series of fixtures in the form of pending patent applications in the US and PCT applications for International protection.

Dimensions

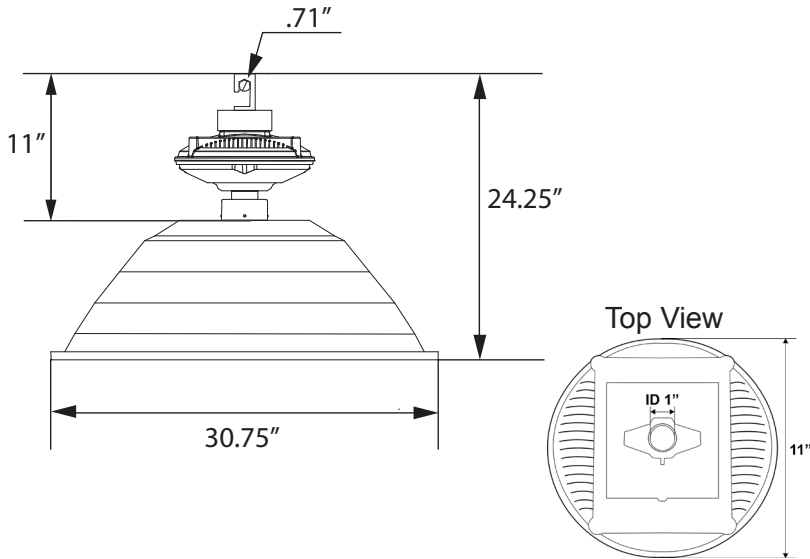

Photometric Data

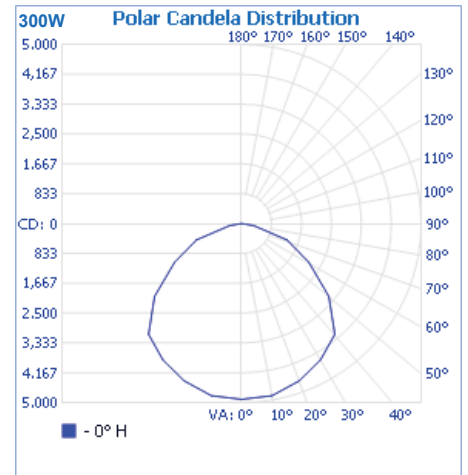

Lamp Specifications

Wattage	Lumens	L/W Ratio	CRI	CCT (KELVIN)	Rated Life
300W	25,200	84	82-85	5000	100,000 hours
400W	33,600	84	82-85	5000	100,000 hours

Ballast Specifications

System Wattage	Input Voltage	Input Current	Input Freq.	Power Factor	Ambient Temp	THD
320W	120-277V/480V*	2.65-1.20A / 0.62A	50/60Hz	>0.95	-20 to 130 F°	<10%
440W	120-277V/480V*	3.54-1.60A / 0.92A	50/60Hz	>0.95	-20 to 130 F°	<10%

Application Image - EHBUS-AC



Detroit Diesel MTU, Aiken SC

*Legal Notice: Full Spectrum Solutions owns proprietary rights in the EverLast® Series of fixtures in the form of pending patent applications in the US and PCT applications for International protection.