

Streamline Contour Cobra

Description

- Series: ECHBC-ED
- Lamp Life Rating: 100,000 hours
- Lumen Maintenance: 70% over 100,000 hours
- Light Output: 5000K, 86-90 CRI
- IP Rating: IP65
- Applications: Freeway, highway, parking lots, public entrances, off-street areas
- Warranty: 10 Year Limited

Specifications and Patent Pending Features

- High pressure die cast aluminum alloy housing for corrosion resistance
- UV stabilized, heat resistant polycarbonate lens
- Vacuum coated, high purity, stretched aluminum reflector provides high reflectivity and even distribution
- Streamline contour contemporary design
- Electronic ballast with high power factor
- Excellent vibration & shock resistance

Ordering Information

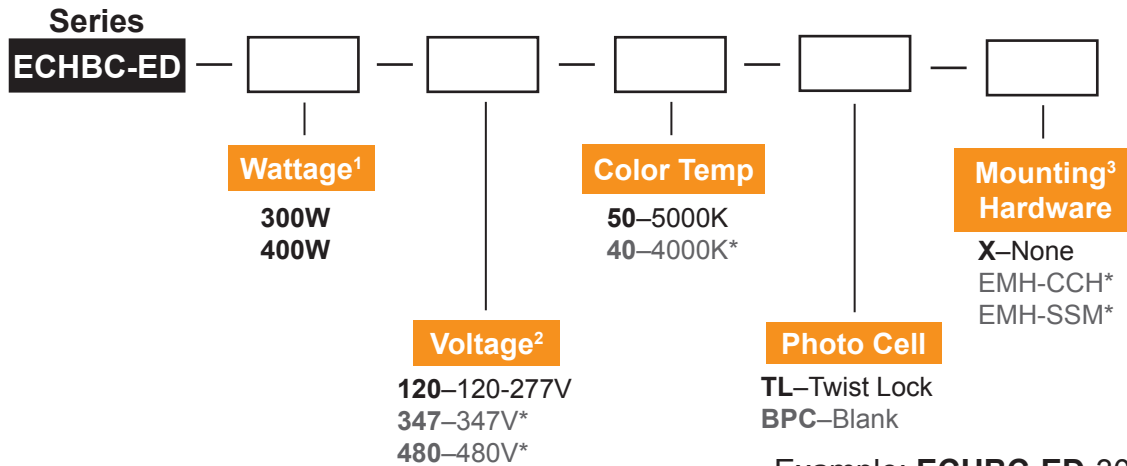

Bold = Standard
Grey * = Upgrade options available upon request

Example: **ECHBC-ED-300-120-50-TL-X**

Recommended Roadway Lighting

Grid Statistics	100W
Average	1.6fc
Max	6.9fc
Min	0.1fc
Avg/Min	16.0

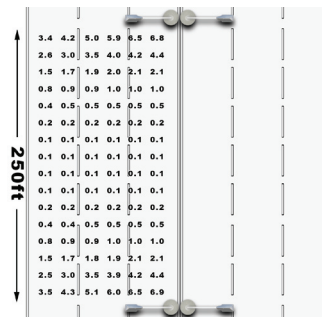

Dimensions

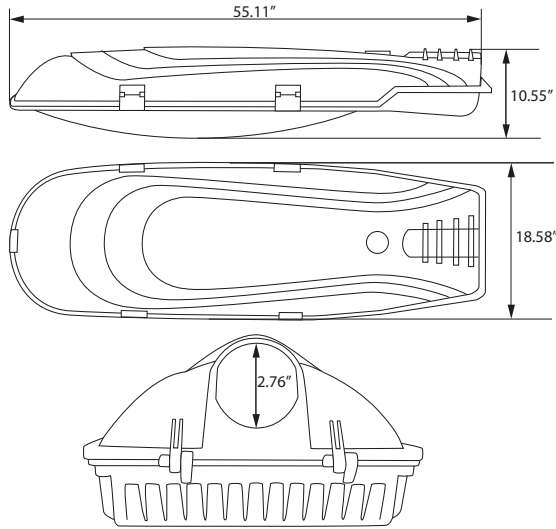

Photometric Data

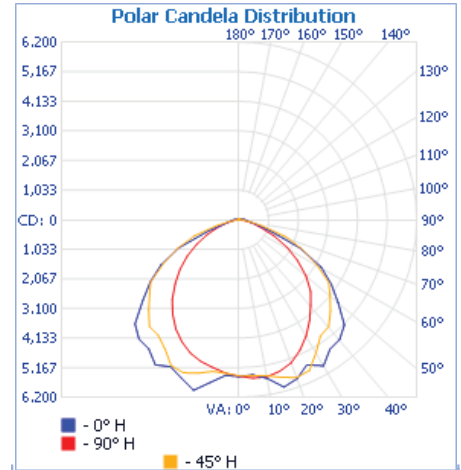

Lamp Specifications

Wattage	Lumens	L/W Ratio	CRI	CCT (KELVIN)	Rated Life
300W	25,200	84	86-90	5000	100,000 hours
400W	33,600	84	82-85	5000	100,000 hours

Ballast Specifications

System Wattage	Input Voltage	Input Current	Input Freq.	Power Factor	Ambient Temp	THD
320W	120-277V/480V*	2.65-1.20A / 0.62A	50/60Hz	>0.95	-40 to 130 F°	<10%
440W	120-277V/480V*	3.54-1.60A / 0.92A	50/60Hz	>0.95	-40 to 130 F°	<10%

Application Image - ECHBC-ED

